

Turbocharger Clutch Drive Gear Assembly

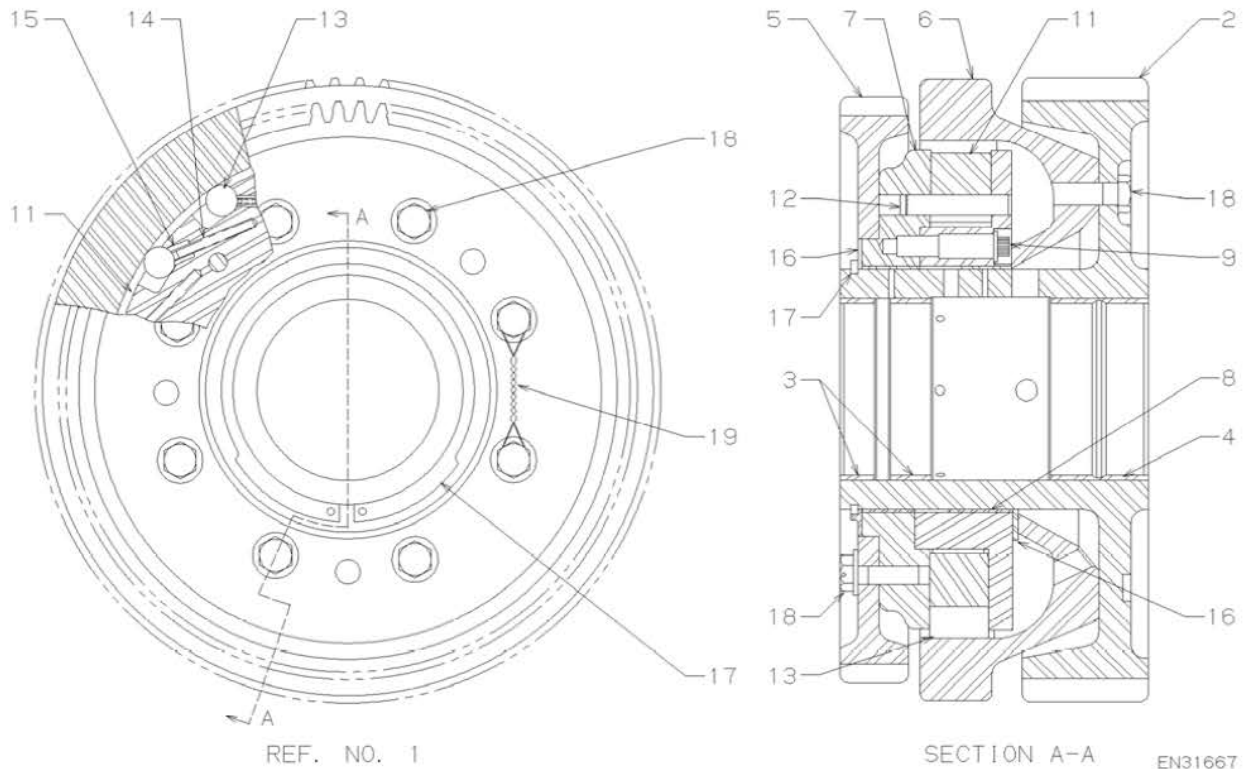

Asm - Ref. No.	Part Number	Qty.	Description
15-1	40004866	1	CLUTCH ASSEMBLY.. Turbocharger drive - Utex No. 40028648
-2	40001038	1	GEAR ASSEMBLY.. Upper idler - 58 Teeth <i>Replacement bearings must be precision bored after assembly.</i>
-3	8407341	2	BEARING.. Hub
-4	8261101	1	BEARING.. Gear
-5	40004869	1	GEAR.. Turbocharger drive - 86 Teeth
-6	40001039	1	SUPPORT.. Clutch drive
-7	40001043	1	DOWELING ASSEMBLY.. Clutch <i>Replacement bearings must be precision bored after assembly.</i>
-8	9534826	2	BEARING.. Clutch
-9	9534825	8	BOLT.. 12 point 3/8-24 x 2-1/4
-10	8329276	1	PIN.. Dowel - 0.3127 diameter x 5/8 inch (not shown) 8375066 .. 0.005 O.S. - 8375067.. 0.010 O.S. - 8375068.. 0.015 O.S.
-11	9534857	1	PLATE.. Cam
-12	40001555	8	PIN.. Dowel - 0.4377 diameter x 2-1/2 inches long 40001556.. 0.002 O.S. - 40001557.. 0.004 O.S. - 40001558.. 0.006 O.S. 40001559.. 0.008 O.S. - 40001560.. 0.010 O.S.
-13	8477363	16	ROLLER.. Clutch
-14	9535617	16	SPRING.. Coil
-15	9536638	16	CUP.. Spring
-16	9534855	2	RING.. Retaining
-17	9414864	1	RING.. Snap
-18	9584413	16	BOLT.. Hex head 5/8-18 x 1-1/2
-19	8116738	AR	WIRE.. Lock - 3/4 diameter x 500 feet