

Assembly 11: ACCESSORY DRIVE GEAR ASSEMBLY

Accessory Drive Gear and Bolt-On Stubshaft Arrangement

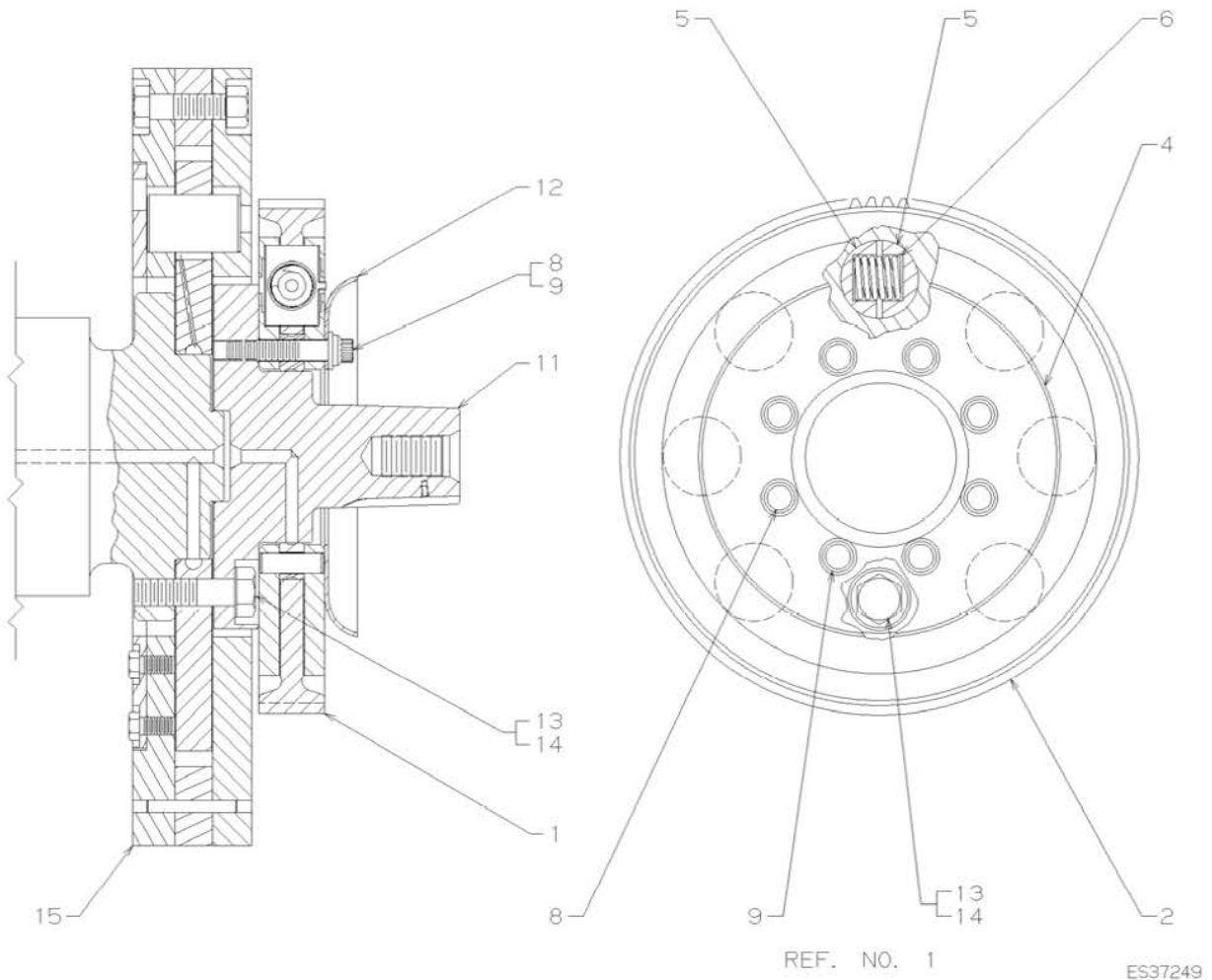

Asm - Ref. No.	Part Number	Qty.	Description
11-1	9320634	1	GEAR ASSEMBLY.. Accessory drive
-2	8360839	1	GEAR.. Accessory drive - Spur
-3	8483064	1	HUB.. Drive gear (not shown)
-4	8483014	1	DISC.. Front
-4	8483015	1	DISC.. Rear
-5	9091463	16	SEGMENT.. Spring
-6	8360837	8	SPRING.. Coil
-7	8483097	2	DOWEL.. Alignment - .626 diameter x 1-15/16 inches long (not shown) 8483098.. 0.005 O.S. - 8483099.. 0.010 O.S. - 8483100.. 0.015 O.S. (optional)
-8	9434253	8	BOLT.. Spline head - 12 point - 5/8-11 x 3-1/4
-9	8483090	8	WASHER.. Special - 1-1/8 O.D. x 21/32 I.D. x 1/8 inch thick
-10	102639	8	NUT.. Hex 5/8-11 - For shipping and storage only (not shown)
-11	9546333	1	STUBSHAFT.. Tapered
-12	8483087	1	SLINGER.. Oil - Accessory drive
-13	223771	8	BOLT.. Hex head 7/8-14 x 3-1/4 - Stubshaft to crankshaft
-14	8174659	8	WASHER.. Special - 1-5/8 O.D. x 15/16 I.D. x 1/8 inch thick
-15	40051110	1	DAMPER ASSEMBLY.. Torsional vibration - See page 1-28